

DH6TE SERIES CONDENSING UNIT HEAT PUMP INSTALLATION & SERVICE REFERENCE

Important Safety Instructions

The following symbols and labels are used throughout this manual to indicate immediate or potential safety hazards. It is the owner's and installer's responsibility to read and comply with all safety information and instructions accompanying these symbols. Failure to heed safety information increases the risk of personal injury, property damage, and/or product damage.

NOTE: This equipment is approved to use only with R-32 refrigerant.

WARNING
<p>ONLY PERSONNEL THAT HAVE BEEN TRAINED TO INSTALL, ADJUST, SERVICE, MAINTENANCE OR REPAIR (HEREINAFTER, "SERVICE") THE EQUIPMENT SPECIFIED IN THIS MANUAL SHOULD SERVICE THE EQUIPMENT.</p> <p>THIS EQUIPMENT IS NOT INTENDED FOR USE BY PERSONS (INCLUDING CHILDREN) WITH REDUCED PHYSICAL, SENSORY OR MENTAL CAPACITIES, OR LACK OF EXPERIENCE AND KNOWLEDGE, UNLESS THEY HAVE BEEN GIVEN SUPERVISION OR INSTRUCTION CONCERNING USE OF THE APPLIANCE BY A PERSON RESPONSIBLE FOR THEIR SAFETY.</p> <p>CHILDREN SHOULD BE SUPERVISED TO ENSURE THAT THEY DO NOT PLAY WITH THE EQUIPMENT.</p> <p>THE MANUFACTURER WILL NOT BE RESPONSIBLE FOR ANY INJURY OR PROPERTY DAMAGE ARISING FROM IMPROPER SUPERVISION, SERVICE OR SERVICE PROCEDURES. IF YOU SERVICE THIS UNIT, YOU ASSUME RESPONSIBILITY FOR ANY INJURY OR PROPERTY DAMAGE WHICH MAY RESULT. IN ADDITION, IN JURISDICTIONS THAT REQUIRE ONE OR MORE LICENSES TO SERVICE THE EQUIPMENT SPECIFIED IN THIS MANUAL, ONLY LICENSED PERSONNEL SHOULD SERVICE THE EQUIPMENT. IMPROPER SUPERVISION, INSTALLATION, ADJUSTMENT, SERVICING, MAINTENANCE OR REPAIR OF THE EQUIPMENT SPECIFIED IN THIS MANUAL, OR ATTEMPTING TO INSTALL, ADJUST, SERVICE OR REPAIR THE EQUIPMENT SPECIFIED IN THIS MANUAL WITHOUT PROPER SUPERVISION OR TRAINING MAY RESULT IN PRODUCT DAMAGE, PROPERTY DAMAGE, PERSONAL INJURY OR DEATH.</p>
WARNING
<p>DO NOT BYPASS SAFETY DEVICES.</p>

WARNING	
<p>HIGH VOLTAGE DISCONNECT ALL POWER BEFORE SERVICING OR INSTALLING THIS UNIT. MULTIPLE POWER SOURCES MAY BE PRESENT. FAILURE TO DO SO MAY CAUSE PROPERTY DAMAGE, PERSONAL INJURY OR DEATH.</p>	
CAUTION	
<p>SCROLL EQUIPPED UNITS SHOULD NEVER BE USED TO EVACUATE THE AIR CONDITIONING SYSTEM. VACUUMS THIS LOW CAN CAUSE INTERNAL ELECTRICAL ARCING RESULTING IN A DAMAGED OR FAILED COMPRESSOR.</p>	

Shipping Inspection

Always keep the unit upright; laying the unit on its side or top may cause equipment damage. Shipping damage, and subsequent investigation is the responsibility of the carrier. Verify the model number, specifications, electrical characteristics, and accessories are correct prior to installation. The distributor or manufacturer will not accept claims from dealers for transportation damage or installation of incorrectly shipped units.

Codes & Regulations

This product is designed and manufactured to comply with national codes. Installation in accordance with such codes and/or prevailing local codes/regulations is the responsibility of the installer. This unit DH6TE090 or DH6TE120 is a partial unit air conditioner, complying with partial unit requirements for international standard IEC 60335-2-40, and must be only connected to other units that have been confirmed as complying to corresponding partial unit requirements of international standard IEC 60335-2-40. The manufacturer assumes no responsibility for equipment installed in violation of any codes or regulations. Rated performance is achieved after 20 hours of operation. Rated performance is delivered at the specified airflow. See outdoor unit specification sheet for split system models or product specification sheet for packaged and light commercial models. Specification sheets can be found at www.daikincomfort.com for Daikin brand products. Within the website, please select the residential or commercial products menu and then select the submenu for the type of product to be installed, such as air conditioners or heat pumps, to access a list of product pages that each contain links to that model's specification sheet.

Our continuing commitment to quality products may mean a change in specifications without notice.

© 2024 **DAIKIN COMFORT TECHNOLOGIES MANUFACTURING, L.P.**





WARNING

DO NOT USE MEANS TO ACCELERATE DEFROSTING PROCESS OR TO CLEAN, OTHER THAN THOSE RECOMMENDED BY THE MANUFACTURER. THE APPLIANCE SHALL BE STORED IN A ROOM WITHOUT CONTINUOUSLY OPERATING IGNITION SOURCES (FOR EXAMPLE: OPEN FLAMES, AN OPERATING GAS APPLIANCE OR AN OPERATING ELECTRIC HEATER).

DO NOT PIERCE OR BURN.

BE AWARE THAT REFRIGERANTS MAY NOT CONTAIN AN ODOR.



WARNING

ONLY AUXILIARY DEVICES APPROVED BY THE APPLIANCE MANUFACTURER OR DECLARED SUITABLE WITH THE REFRIGERANT SHALL BE INSTALLED IN CONNECTING DUCTWORK.



WARNING

THIS UNIT IS EQUIPPED WITH ELECTRICALLY POWERED SAFETY MEASURES. TO BE EFFECTIVE, THE UNIT MUST BE ELECTRICALLY POWERED AT ALL TIMES AFTER INSTALLATION, OTHER THAN WHEN SERVICING.



WARNING

HIGH VOLTAGE
PRIOR TO SERVICING THE UNIT OR REMOVING THE COMPRESSOR TERMINAL PLUG OR TERMINAL COVER, DISCONNECT ALL ELECTRICAL POWER FROM THE UNIT. MULTIPLE POWER SOURCES MAY BE PRESENT.



QUALIFICATION OF WORKERS

Personnel must be certified to service, work, and/or repair units with FLAMMABLE REFRIGERANTS. A certificate should document the competence and qualification achieved through training that included the substance of the following:

- Information about the explosion potential of FLAMMABLE REFRIGERANTS to show that flammables may be dangerous when handled without care.
- Information about POTENTIAL IGNITION SOURCES, especially those that are not obvious, such as lighters, light switches, vacuum cleaners, electric heaters.
- Information about the different safety concepts, including ventilated and unventilated areas.
- Information about refrigerant detectors, including function, operation, and service measures.
- Information about the concept of sealed components and sealed enclosures according to IEC 60079-15:2010.
- Information about the correct working procedures, including commissioning, maintenance, repair, decommissioning, and disposal procedures.



WARNING

DO NOT OPERATE THE COMPRESSOR(S) WITHOUT THE TERMINAL PLUG FULLY ENGAGED OR THE TERMINAL COVER PROPERLY INSTALLED. GET AWAY IF UNUSUAL SOUNDS ARE HEARD FROM WITHIN THE COMPRESSOR. DISCONNECT ELECTRICAL POWER FROM THE COMPRESSOR/UNIT.



WARNING

A TRIPPED CIRCUIT BREAKER OR BLOWN FUSE MAY INDICATE THAT AN ELECTRICAL PROBLEM EXISTS.

DO NOT RESET A CIRCUIT BREAKER OR REPLACE FUSES WITHOUT FIRST PERFORMING THOROUGH ELECTRICAL TROUBLESHOOTING AND TESTING PROCEDURES.

SYSTEM SERVICE AND DECOMMISSIONING

Should repairs requiring recovery of the refrigerant become necessary, special considerations must be made when breaking into systems with flammable refrigerants. These repairs shall only be performed by qualified service personnel and in compliance with local and national regulations.

The refrigerant charge shall only be recovered into a cylinder labeled for use with R-32. Ensure that the refrigerant cylinder(s) are capable of holding the total system charge. Cylinders shall be complete with a pressure-relief valve and associated shut-off valves in good working order. Empty recovery cylinders are evacuated and, if possible, cooled before recovery occurs. A set of calibrated weighing scales shall be available and in good working order. Hoses shall be complete with leak-free disconnect couplings and in good condition.

All best practices for refrigerant recovery must be followed, including use of a recovery machine designated safe for use with A2L refrigerants. Isolate the system electrically prior to recovery. Ensure that all personal protective equipment is being applied correctly. Ensure that all electric sources are disconnect and lockedout/taggedout. Ensure that the recovery process is supervised at all times by a qualified servicer. Situate the R-32 cylinder on the scale before recovery takes place. Start the recovery machine and operate in accordance with its instructions. Do not overfill cylinders by more than 80% volume of its allowed liquid charge.

Markings and warnings on the unit shall continue to be visible and legible after installation and service. Correct any markings and warnings that are made illegible.

When decommissioning a system, all previously mentioned precautions regarding safe refrigerant handling must be followed. Recovered refrigerant shall not be charged into another refrigerating system unless it has been cleaned and checked. Equipment must be labeled, dated, and signed stating that it has been decommissioned and emptied of refrigerant.



WARNING

HERMETIC COMPRESSOR ELECTRICAL TERMINAL VENTING CAN BE DANGEROUS. IN CERTAIN CIRCUMSTANCES, THE TERMINAL MAY BE EXPELLED, VENTING THE REFRIGERANT VAPOR AND COMPRESSOR OIL CONTAINED WITHIN THE COMPRESSOR HOUSING AND SYSTEM. BE ALERT FOR SOUNDS OF ARCING (SIZZLING, SPATTERING, OR POPPING) INSIDE THE COMPRESSOR. IMMEDIATELY GET AWAY IF YOU HEAR THESE SOUNDS AND DISCONNECT ELECTRICAL POWER FROM THE COMPRESSOR/UNIT.

TERMINAL VENTING

Never operate the compressor without the terminal cover secured and properly in place or without the electrical plug fully seated and engaged to the terminal posts.

NOTE: NEVER OPERATE COMPRESSOR IN VACUUM OR IN REVERSE ROTATION.

If a terminal is damaged, electrically overloaded, or short circuits to ground, there is a remote possibility that the terminal can be suddenly expelled from the terminal housing thereby venting the refrigerant and compressor oil mixture to atmosphere.

This discharge can be ignited from electrical arcing, or other open sources of ignition, and can cause potentially severe or fatal injury. This event is known as Terminal Venting.

To reduce the possibility of external ignition, all open flames or other heat sources must be extinguished, and all electrical power must be turned off prior to opening the terminal cover or removing the electrical plug and servicing the system.

Proper sealed system evacuation is required during equipment installation and servicing to maintain adequate internal system cleanliness while eliminating contaminants. Be alert for sounds of arcing (sizzling, spattering, or popping) inside the compressor. IMMEDIATELY GET AWAY from the unit if you hear these sounds and disconnect electrical power.

The United States Environmental Protection Agency (EPA) has issued various regulations regarding the introduction and disposal of refrigerants. Failure to follow these regulations may harm the environment and can lead to the imposition of substantial fines.

Should you have any questions please contact the local office of the EPA.

If replacing a condensing unit or air handler, the system must be manufacturer approved and Air Conditioning and Refrigeration Institute (AHRI) matched. NOTE: Installation of unmatched systems is strongly discouraged.

Outdoor units are approved for operation above 55°F in cooling mode. Operation below 55°F in cooling mode requires the use of an approved low ambient kit.

Damage to the unit caused by operating the unit in a structure that is not complete (either as part of new construction or renovation) is not covered under the warranty.

Refer to the unit Specification Sheet for the recommended indoor model selection. **NOTE:** This unit must be used with a purchased two stage room thermostat with 24 VAC control circuitry.

Installation Clearances

This unit is designed for outdoor installations only. Special consideration must be given to location of the condensing unit(s) in regard to structures, obstructions, other units, and any/all other factors that may interfere with air circulation. Where possible, the top of the unit should be completely unobstructed; however, if vertical conditions require placement beneath an obstruction **there should be a minimum of 60 inches between the top of the unit and the obstruction(s)**. The specified dimensions meet requirements for air circulation only. Consult all appropriate regulatory codes prior to determining final clearances.

Another important consideration in selecting a location for the unit(s) is the angle to obstructions. Either side adjacent the valves can be placed toward the structure provided the side away from the structure maintains minimum service clearance. Corner installations are strongly discouraged.

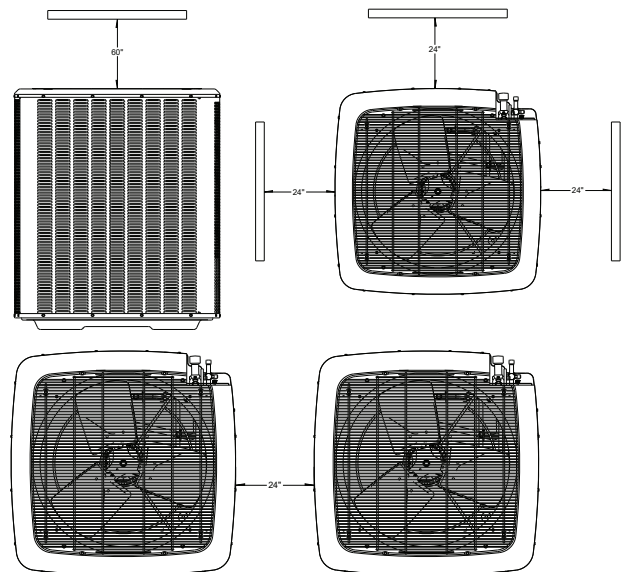

This unit can be located at ground floor level or on flat roofs. At ground floor level, the unit must be on a solid, level foundation that will not shift or settle. To reduce the possibility of sound transmission, the foundation slab should not be in contact with or be an integral part of the building foundation. The foundation slab should be a minimum of 6" wider than the unit in all directions. Ensure the foundation is sufficient to support the unit. A concrete slab raised above ground level provides a suitable base. For optimum performance, the minimum length interconnecting tubing is preferred. When possible minimize the amount of bends and turns.

Rooftop Installations

If it is necessary to install this unit on a roof structure, ensure the roof structure can support the weight and that proper consideration is given to the weather-tight integrity of the roof. Since the unit can vibrate during operation, sound vibration transmission should be considered when installing the unit. Vibration absorbing pads or springs can be installed between the condensing unit legs or frame and the roof mounting assembly to reduce noise vibration.

NOTE: These units require special location consideration in areas of heavy snow accumulation and/or areas with prolonged continuous subfreezing temperatures. These unit bases have cutouts under the outdoor coil that permit drainage of frost accumulation. Situate the unit to permit free unobstructed drainage of the defrost water and ice. A minimum 3" clearance under the outdoor coil is required in the milder climates. In more severe weather locations, it is recommended that the unit be elevated to allow unobstructed drainage and air flow. In areas of heavy snow the unit needs to be elevated above the average yearly snow accumulation.

Rigging



WARNING

TO AVOID POSSIBLE INJURY OR DEATH, ALL PANELS MUST BE IN POSITION AND SECURED BEFORE LIFTING THIS EQUIPMENT.

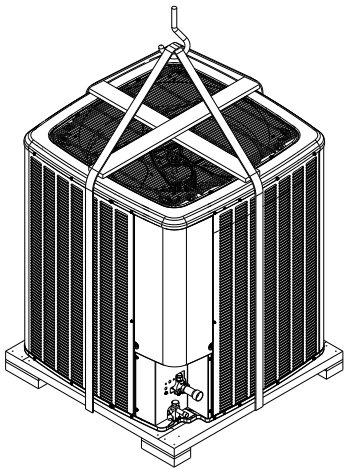

Use field-supplied spreader bars when lifting the unit to minimize the possibility of lifting cable/straps damage. To protect the cabinet louvers, use protective material such as plywood behind the cable/straps. Arrange the straps to form a central suspension point. **NOTE:** When raising and setting the unit, observe all safety rules. Remove shipping skid and all protection and lifting material after the unit is in place.

Safe Refrigerant Handling

While these items will not cover every conceivable situation, they should serve as a useful guide.



WARNING

TO AVOID POSSIBLE INJURY, EXPLOSION OR DEATH, PRACTICE SAFE HANDLING OF REFRIGERANTS.



WARNING

PARTIAL UNITS SHALL ONLY BE CONNECTED TO APPLIANCE SUITABLE FOR THE SAME REFRIGERANT.



WARNING

REFRIGERANTS ARE HEAVIER THAN AIR. THEY CAN "PUSH OUT" THE OXYGEN IN YOUR LUNGS OR ANY ENCLOSED SPACE. TO AVOID POSSIBLE DIFFICULTY IN BREATHING OR DEATH:

- NEVER PURGE REFRIGERANT INTO AN ENCLOSED ROOM OR SPACE. BY LAW, ALL REFRIGERANTS MUST BE RECLAIMED.
- IF AN INDOOR LEAK IS SUSPECTED, THOROUGHLY VENTILATE THE AREA BEFORE BEGINNING WORK.
- LIQUID REFRIGERANT CAN BE VERY COLD. TO AVOID POSSIBLE FROSTBITE OR BLINDNESS, AVOID CONTACT AND WEAR GLOVES AND GOGGLES. IF LIQUID REFRIGERANT DOES CONTACT YOUR SKIN OR EYES, SEEK MEDICAL HELP IMMEDIATELY.
- ALWAYS FOLLOW EPA REGULATIONS. NEVER BURN REFRIGERANT, AS POISONOUS GAS WILL BE PRODUCED.



WARNING

TO AVOID POSSIBLE EXPLOSION:

- NEVER APPLY FLAME OR STEAM TO A REFRIGERANT CYLINDER. IF YOU MUST HEAT A CYLINDER FOR FASTER CHARGING, PARTIALLY IMMERSE IT IN WARM WATER.
- NEVER FILL A CYLINDER MORE THAN 80% FULL OF LIQUID REFRIGERANT.
- NEVER ADD ANYTHING OTHER THAN R-32 TO AN R-32 CYLINDER. THE SERVICE EQUIPMENT USED MUST BE LISTED OR CERTIFIED FOR THE TYPE OF REFRIGERANT USED.
- STORE CYLINDERS IN A COOL, DRY PLACE. NEVER USE A CYLINDER AS A PLATFORM OR A ROLLER.



WARNING

TO AVOID POSSIBLE EXPLOSION, USE ONLY RETURNABLE (NOT DISPOSABLE) SERVICE CYLINDERS WHEN REMOVING REFRIGERANT FROM A SYSTEM.

- ENSURE THE CYLINDER IS FREE OF DAMAGE WHICH COULD LEAD TO A LEAK OR EXPLOSION.
- ENSURE THE HYDROSTATIC TEST DATE DOES NOT EXCEED 5 YEARS.
- ENSURE THE PRESSURE RATING MEETS OR EXCEEDS 400 PSIG.

WHEN IN DOUBT, DO NOT USE A CYLINDER.



CAUTION

THE COMPRESSOR POE OIL FOR R-32 UNITS IS EXTREMELY SUSCEPTIBLE TO MOISTURE ABSORPTION AND COULD CAUSE COMPRESSOR FAILURE. DO NOT LEAVE SYSTEM OPEN TO ATMOSPHERE ANY LONGER THAN NECESSARY FOR INSTALLATION.

Refrigerant Lines

NOTE: For improved refrigerant management, equip the liquid line with a field-supplied liquid line solenoid.

Ensure the solenoid is installed as close as possible to the evaporator coil to prevent refrigeration migration in the compressor "OFF" cycle. The maximum allowable pressure shall be considered when connecting to a condenser or evaporator unit.

Use only refrigerant grade (dehydrated and sealed) copper tubing to connect the condensing unit with the indoor evaporator. After cutting the tubing, install plugs to keep refrigerant tubing clean and dry prior to and during installation. Tubing should always be cut square keeping ends round and free from burrs. Clean the tubing to prevent contamination.

Do NOT let refrigerant lines come in direct contact with plumbing, ductwork, floor joists, wall studs, floors, and walls. When running refrigerant lines through a foundation or wall, openings should allow for sound and vibration absorbing material to be placed or installed between tubing and foundation. Any gap between foundation or wall and refrigerant lines should be filled with a pliable silicon-based caulk, RTV or a vibration damping material. Avoid suspending refrigerant tubing from joists and studs with rigid wire or straps that would come in contact with the tubing. Use an insulated or suspension type hanger. Keep both lines separate and always insulate the suction line.

Use the following guidelines to size line sets:

- All Vertical lines: 1-1/8 in.
- Horizontal lines: 1-1/8 in. (7.5 ton), 1-3/8 in. (10 ton)
- Liquid line: 5/8 in.
- Maximum line length: 150 ft
- Maximum vertical lift: 25 ft
- Full load ratings: 25 ft

NOTE: For variations to the above, see TP-111 Long Line Set Application Guideline or contact your local distributor for assistance.

Refrigerant Lines

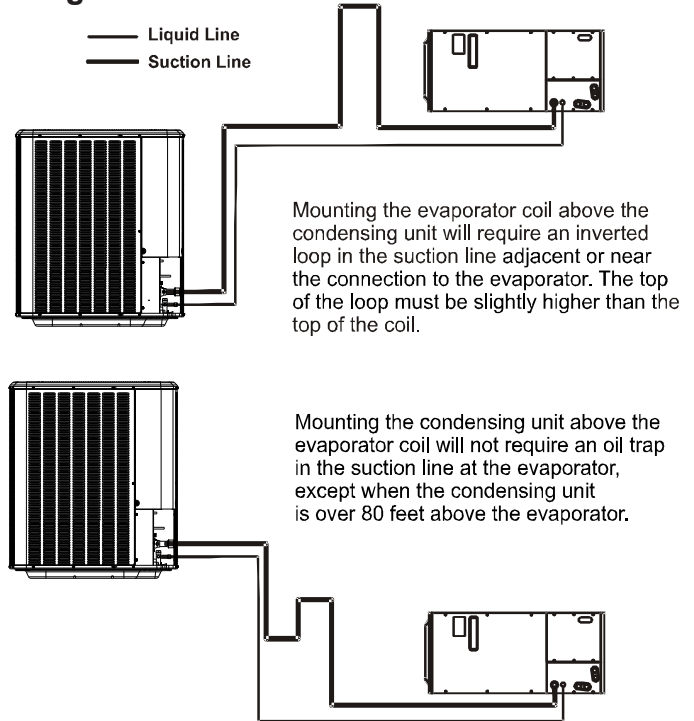

Insulation is necessary to prevent condensation from forming and dripping from the suction line. Armflex® (or satisfactory equivalent) with $\frac{3}{8}$ " min. wall thickness is recommended. In severe conditions (hot, high humidity areas) $\frac{1}{2}$ " insulation may be required. Insulation must be installed in a manner which protects tubing from damage and contamination.

Where possible, drain as much residual compressor oil from existing systems, lines, and traps; pay close attention to low areas where oil may collect.

NOTE: If changing refrigerant types, ensure the indoor coil and metering device is compatible with the type of refrigerant being used; otherwise, the indoor coil must be replaced. To facilitate oil return to the compressor, a horizontal suction line should be pitched ($\frac{1}{2}$ " per 10' toward the condensing unit).

FILTER DRIER AND SIGHT GLASS

A liquid line filter drier is factory installed. Field-install the supplied sight glass/moisture indicator on the liquid line as close as practical to the service valve.

Burying Refrigerant Lines

If burying refrigerant lines can not be avoided, use the following checklist.

1. Insulate liquid and suction lines separately.
2. Enclose all underground portions of the refrigerant lines in waterproof material (conduit or pipe) sealing the ends where tubing enters/exits the enclosure.
3. If the lines must pass under or through a concrete slab, ensure lines are adequately protected and sealed.

Refrigerant Line Connections

IMPORTANT: To avoid overheating the service valve, TXV valve, or filter drier while brazing, wrap the component with a wet rag, or use a thermal heat trap compound as recommended by the compound manufacturer. Use a brazing alloy of 2% minimum silver content. Do not use flux.

1. The ends of the refrigerant lines must be cut square, deburred, cleaned, and be round and free from nicks or dents. Any other condition increases the chance of a refrigerant leak.
2. This unit is factory shipped with a holding charge. "Sweep" the refrigerant line with nitrogen or inert gas during brazing to prevent the formation of copper-oxide inside the refrigerant lines.
3. After brazing, quench the joints with water or a wet cloth to prevent overheating of the service valve.
4. Ensure the filter drier paint finish is intact after brazing. If the paint of the steel filter drier has been burned or chipped, repaint or treat with a rust preventative. This is especially important on suction line filter driers which are continually wet when the unit is operating.

NOTE: Be careful not to kink or dent refrigerant lines. Kinked or dented lines will cause poor performance or compressor damage.

Do NOT make final refrigerant line connection until plugs are removed from refrigerant tubing

Leak Testing (Nitrogen or Nitrogen-Traced)



WARNING

TO AVOID THE RISK OF FIRE OR EXPLOSION, NEVER USE OXYGEN HIGH PRESSURE AIR OR FLAMMABLE GASES FOR LEAK TESTING OF A REFRIGERATION SYSTEM.



WARNING

TO AVOID POSSIBLE EXPLOSION, THE LINE FROM THE NITROGEN CYLINDER MUST INCLUDE A PRESSURE REGULATOR AND A PRESSURE RELIEF VALVE. THE PRESSURE RELIEF VALVE MUST BE SET TO OPEN AT NO MORE THAN 150 PSIG.

DETECTION OF FLAMMABLE REFRIGERANTS

Under no circumstances shall potential sources of ignition be used in the searching for or detection of refrigerant leaks. A halide torch (or any other detector using a naked flame) shall not be used. The following leak detection methods are deemed acceptable for all refrigerant systems.

Pressure test the system using dry nitrogen and soapy water to locate leaks. If you wish to use a leak detector, charge the system to 10 psi using the appropriate refrigerant then use nitrogen to finish charging the system to working pressure then apply the detector to suspect areas. If leaks are found, repair them. After repair, repeat the pressure test. If no leaks exist, proceed to system evacuation.

System Evacuation

Condensing unit liquid and suction valves are closed to contain the charge within the unit. The unit is shipped with the valve stems closed and caps installed. Do not open valves until the system is evacuated.



WARNING

REFRIGERANT UNDER PRESSURE!

FAILURE TO FOLLOW PROPER PROCEDURES MAY CAUSE PROPERTY DAMAGE, PERSONAL INJURY OR DEATH.

1. Connect the vacuum pump with 250 micron capability to the service valves.
2. Evacuate the system to 250 microns or less using suction and liquid service valves. Using both valves is necessary as some compressors create a mechanical seal separating the sides of the system.
3. Close pump valve and hold vacuum for 10 minutes. Typically pressure will rise during this period.
 - If the pressure rises to 1000 microns or less and remains steady the system is considered leak-free; proceed to startup.
 - If pressure rises above 1000 microns but holds steady below 2000 microns, moisture and/or noncondensibles may be present or the system may have a small leak. Return to step 2: If the same result is encountered check for leaks as previously indicated and repair as necessary then repeat evacuation.
 - If pressure rises above 2000 microns, a leak is present. Check for leaks as previously indicated and repair as necessary then repeat evacuation.

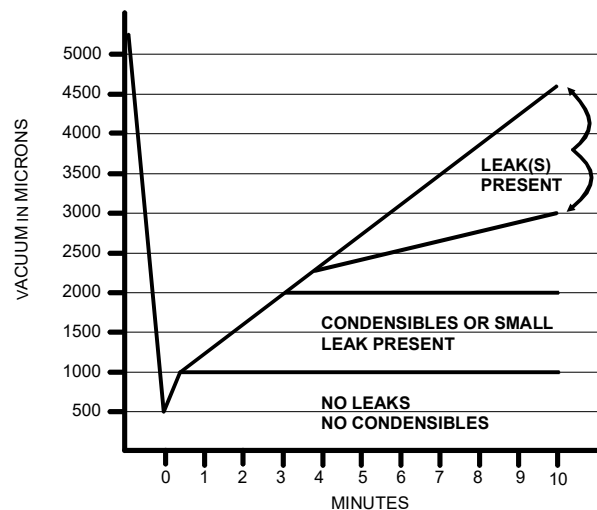

Refer to the Remote Condensing Unit Service Manual for more detailed instructions on system evacuation, preliminary charge adjustment, and final charge adjustment.

THE FOLLOWING INSTRUCTIONS ARE MANDATORY FOR A2L SYSTEMS AND SUPERSEDE OTHER INSTRUCTIONS

WARNING

ONLY BRAZING TECHNIQUES AND APPROVED MECHANICAL JOINTS SHOULD BE USED TO CONNECT REFRIGERANT TUBING CONNECTIONS. NON-APPROVED MECHANICAL CONNECTORS AND OTHER METHODS ARE NOT PERMITTED IN THIS SYSTEM CONTAINING A2L REFRIGERANT. APPROVED MECHANICAL JOINTS WILL BE DETAILED IN THE PRODUCT'S SPECIFICATION SHEETS.

STANDING PRESSURE TEST/ LEAK DETECTION METHOD

Using dry nitrogen or dry helium, pressurize the system to 450 PSIG. Allow the pressure to stabilize and hold for 15 Minutes (minimum). The system is considered leak-free if the pressure does not drop below 450 PSIG. If, after 15 Minutes, the pressure drops below 450 PSIG, it implies a leak in the system. Proceed with identifying and sealing the leak and repeating the Standing Pressure Test. Leak test the system using dry nitrogen or dry helium and soapy water to identify leaks. **No refrigerant shall be used for pressure testing to detect leaks.** Proceed to system evacuation using the Deep Vacuum Method.

DEEP VACUUM METHOD

The Deep Vacuum Method requires a vacuum pump rated for 500 microns or less. This method effectively and efficiently ensures the system is free of non-condensable air and moisture. The Triple Evacuation Method is detailed in the Service Manual for this product model as an alternative. To expedite the evacuation procedure, it is recommended that the Schrader Cores be removed from the service valves using a core-removal tool.

1. Connect the vacuum pump, micron gauge, and vacuum-rated hoses to both service valves. Evacuation must use both service valves to eliminate system mechanical seals.
2. Evacuate the system to less than 500 microns.
3. Isolate the pump from the system and hold the vacuum for 10 minutes (minimum). Typically, pressure will rise slowly during this period. If the pressure rises to less than 1000 microns and remains steady, the system is considered leak-free; proceed to system charging and startup.
4. If pressure rises above 1000 microns but holds steady below 2000 microns, non-condensable air or moisture may remain, or a small leak may be present. Return to step 2: If the same result is achieved, check for leaks and repair. Repeat the evacuation procedure.
5. If pressure rises above 2000 microns, a leak is present. Check for leaks and repair them. Then, repeat the evacuation procedure.

ACCESSORY INSTALLATION

WARNING

ALL ACCESSORIES THAT MAY BECOME A POTENTIAL IGNITION SOURCE IF INSTALLED, SUCH AS ELECTRONIC AIR CLEANERS, MUST ONLY BE POWERED THROUGH OUR ACCESSORY CONTROL BOARD KIT. IF AN ELECTRONIC AIR CLEANER IS ALREADY INSTALLED IN THE DUCT WORK AND NOT CONNECTED TO THE ACCESSORY CONTROL BOARD, IT WILL HAVE TO BE DISABLED OR REMOVED. ENSURE THAT ANY ADDITIONAL WIRING FROM THE INDOOR UNIT TO THE ACCESSORY CONTROL BOARD IS ROUTED AND PROTECTED FROM DAMAGE AND WEAR, AVOIDING THE FLUE PIPE AND ANY JOINTS THAT MAY NEED BRAZED OR DISCONNECTED FOR SERVICE. REFER TO THE PRODUCT SPECIFICATION SHEET FOR THE ACCESSORY CONTROL BOARD KIT PART NUMBER

ALTITUDE ADJUSTMENT FACTOR TO CALCULATE MINIMUM ROOM AREA



The Indoor equipment mitigation requirements are calculated at sea level. For higher altitudes adjust the minimum room area specified on or near the Serial Plate or in the installation instruction manual by the corresponding altitude adjustment factor shown below. This table is provided as a reference.

Adjusted room area ($A_{min\ adj}$) is the product of the minimum room area specified in the serial plate and the adjustment factor AF, as shown in below formula

$$A_{min\ adj} = A_{min} (\text{serial plate}) * AF$$

Height in meters	Height in feet	Altitude Adjustment Factor (AF)
At sea level	At sea level	1.00
1~200	1~660	1.02
200~400	660~1320	1.03
400~600	1320~1970	1.05
600~800	1970~2630	1.07
800~1000	2630~3290	1.09
1000~1200	3290~3940	1.11
1200~1400	3940~4600	1.13
1400~1600	4600~5250	1.15
1600~1800	5250~5910	1.17
1800~2000	5910~6570	1.19
2000~2200	6570~7220	1.21
2200~2400	7220~7880	1.24
2400~2600	7880~8540	1.26
2600~2800	8540~9190	1.29
2800~3000	9190~9850	1.31
3000~3200	9850~10500	1.34

Electrical Connections

 WARNING
<p>HIGH VOLTAGE! DISCONNECT ALL POWER BEFORE SERVICING. MULTIPLE POWER SOURCES MAY BE PRESENT. FAILURE TO DO SO MAY CAUSE PROPERTY DAMAGE, PERSONAL INJURY OR DEATH DUE TO ELECTRIC SHOCK. WIRING MUST CONFORM WITH NEC OR CEC AND ALL LOCAL CODES. UNDERSIZED WIRES COULD CAUSE POOR EQUIPMENT PERFORMANCE, EQUIPMENT DAMAGE OR FIRE.</p>

 WARNING
<p>TO AVOID THE RISK OF FIRE OR EQUIPMENT DAMAGE, USE COPPER CONDUCTORS.</p>

This unit is designed for three phase operation. DO NOT OPERATE ON A SINGLE PHASE POWER SUPPLY. Measure the power supply to the unit. The supply voltage must be in agreement with the unit rating plate power requirements and within the range listed below:

Rated Voltage	Minimum Supply Voltage	Maximum Supply Voltage
208 / 230V	187	253
460V	414	506

The condensing unit rating plate lists pertinent electrical data necessary for proper electrical service and overcurrent protection. Wires should be sized to limit voltage drop to 2% (max.) from the main breaker or fuse panel to the condensing unit. Consult the NEC, CEC, and all local codes to determine the correct wire gauge and length. The wire size must be sufficient to carry the Minimum Circuit Ampacity (MCA) listed on the serial plate.

The supply voltage can be unbalanced (phase to phase) within 2%. The following formula can be used to determine the percentage of voltage unbalance for your unit.

$$\text{Percentage Voltage Unbalance} = \frac{\text{Max. Voltage Deviation From Average Voltage}}{\text{Average Voltage}}$$

Example:

$$\begin{aligned} L1 - L2 &= 220 \text{ V} \\ L2 - L3 &= 216 \text{ V} \end{aligned}$$

$$\begin{aligned} \text{Average Voltage:} &= (220+216+213) / 3 \\ &= 649 / 3 \end{aligned}$$

$$\text{Maximum Deviation from Average} = 220 - 216 = 4$$

$$\begin{aligned} \% \text{ Voltage Unbalance} &= 100 \times (4 / 216) \\ &= 400 / 216 \end{aligned}$$

MAXIMUM ALLOWABLE LENGTH IN FEET TO LIMIT VOLTAGE DROP TO 2% (COPPER CONDUCTOR)

Wire Size (AWG)	Minimum Circuit Ampacity (MCA)							
	10	15	20	25	30	35	40	45
14	77	51	38	NR	NR	NR	NR	NR
12	122	81	61	49	NR	NR	NR	NR
10	193	129	97	77	64	55	NR	NR
8	307	205	154	123	103	88	77	68
6	489	326	244	195	163	140	122	109

Example:

A 7 ½ Ton unit is to be installed. The distance from the building to the unit is 75'. Calculate the minimum wire size assuming no more than 2% voltage drop.

MCA for 7 ½ Ton 230V unit = 43.3 (from S&R plate).

Applying previous table wire sizes less than #8 AWG cannot be used for circuits which have a rating of 45A. The #8 wire is not suitable since the maximum length for a 45A circuit is 68'.

Solution: Use a #6 AWG wire suitable up to 109'.

NOTE: It is the contractor's responsibility to follow the NEC (USA) or CEC (Canada) when sizing the service wire for this unit.

*Always refer to the unit's S&R plate for actual ratings.

Local codes often require a disconnect switch located near the unit; do not install the switch on the unit. Full disconnection from the supply mains having contact separation in all poles equivalent to overvoltage III category must be installed in the fixed wiring in accordance with national wiring regulations. Refer to the installation instructions supplied with the indoor furnace/air handler for specific wiring connections and indoor unit configuration. Likewise, consult the instructions packaged with the thermostat for mounting and location information.

Overcurrent Protection

The following overcurrent protection devices are approved for use.

- Time delay fuses
- HACR type circuit breakers

These devices have sufficient time delay to permit the motor-compressor to start and accelerate its load.

Refer to the unit serial plate for the maximum overcurrent protection permitted.

Run all line voltage wiring and conduit from the service disconnect box to the unit. Refer to the NEC (USA) or CEC (Canada) codes for the correct size conduit based on the wire size. The conduit enters the control box through the hole provided in the bottom. **NOTE:** The control box hole is sized for 3/4" conduit. If permitted by code, a flexible conduit is preferred to minimize vibration transmission from the unit to the building.

Connect the line voltage wires to the L1, L2, and L3 terminals of the definite purpose contactor (located in the unit control box). Refer to the wiring diagram attached to the unit when making these connections.

Three Phase Compressor Rotation

	WARNING
USE CARE WHEN HANDLING SCROLL COMPRESSORS. DOME TEMPERATURES COULD BE HOT.	

Verify proper rotation for three phase compressors by ensuring the suction pressure drops and discharge pressure rises when the compressor is energized.

NOTE: When operated in reverse, a three phase scroll compressors is noisier and its current draw substantially reduced compared to marked values.

To correct, disconnect power and switch any two leads of the line voltage at the contactor and retest.

High Voltage Connections

Route power supply and ground wires through the high voltage port and terminate in accordance with the wiring diagram provided inside the control panel cover.

Low Voltage Connections

Low voltage control wiring should be no smaller than 18 AWG. Field connections must be made inside the control box with solder-less connectors (wire nuts). See the following diagram for a recommended low voltage wiring schematic. The wires running to the condensing unit can be sourced from either the indoor unit's terminal block, or the thermostat.

NOTE: If a two stage auxiliary electric heater kit is installed, only stage one will operate during defrost mode. To activate both auxiliary heating stages during defrost mode, add an 18 AWG jumper wire connecting W1 and W2 on the indoor unit's terminal block.

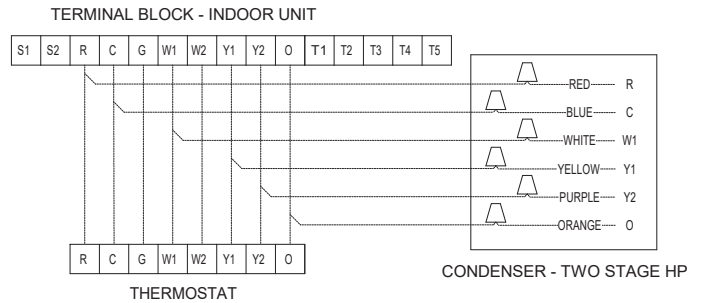

Check that wiring will not be subject to wear, corrosion, excessive pressure, vibration, sharp edges or any other adverse environmental effects. The check shall also take into account the effects of aging or continual vibration from sources such as compressors or fans.

System Start Up

Never operate the compressor with the suction valve closed to test the compressor's pumping efficiency. In some cases, this can result in serious compressor damage.

7-1/2 ton unit starting charge should be 19.1 lbs. of R-32 and 19.3 lbs. for the 10 ton unit for 25 foot line sets. Example: Starting Charge = Holding Charge + Additional Charge for 7-1/2 ton: 19.1 = 6.9 + 12.2.

For any additional line set length see the table below. The length of line set, indoor unit airflow, condensing unit location and number of tubing fittings will have an impact on final unit charge amount. The unit comes with a holding charge of 110 oz. Turn the electrical power on, and let the system run. Wait for the refrigerant pressures to stabilize.

Line Set Combinations	Refrig. Charge per Lineal Foot- Liquid & Gas (Oz)	R32 Refrigerant Charge (Oz) for Lineal Line Set Length - (Ft)							
		25	50	75	100	125	150	175	200
5/8 Liquid Line + 1-1/8 Suction Line	1.54	38.5	77.0	115.5	154.0	192.6	231.1	269.6	308.1
5/8 Liquid Line + 1-3/8 Suction Line	1.62	40.4	80.9	121.3	161.7	202.1	242.6	283.0	323.4
5/8 Liquid Line + 1-5/8 Suction Line	1.71	42.7	85.5	128.2	171.0	213.7	256.5	299.2	342.0
Not Recommended									

NOTE:

1. For any additional charge over 20 lbs add 0.3 oz of compressor oil for each additional lb. of refrigerant
2. Polyol Ester (POE) Oil is used in the scroll compressors. Use Lubrizol, Icematic NXG 5020 (IBC) 999-5171-63 or equivalent.



[symbol ISO 7000-0790 (2004-01)]

read operator's manual



[symbol IEC 60417-5180 (2003-02)]

Class III appliance

Charge Verification



WARNING

REFRIGERANT UNDER PRESSURE!

- Do NOT OVERCHARGE SYSTEM WITH REFRIGERANT.
- Do NOT OPERATE UNIT IN A VACUUM OR AT NEGATIVE PRESSURE.

FAILURE TO FOLLOW PROPER PROCEDURES MAY CAUSE PROPERTY DAMAGE, PERSONAL INJURY OR DEATH.



CAUTION

USE REFRIGERANT CERTIFIED TO AHRI STANDARDS. USED REFRIGERANT MAY CAUSE COMPRESSOR DAMAGE. MOST PORTABLE MACHINES CANNOT CLEAN USED REFRIGERANT TO MEET AHRI STANDARDS.

NOTICE: Violation of EPA regulations may result in fines or other penalties.



CAUTION

DAMAGE TO THE UNIT CAUSED BY OPERATING THE COMPRESSOR WITH THE SUCTION VALVE CLOSED IS NOT COVERED UNDER THE WARRANTY AND MAY CAUSE SERIOUS COMPRESSOR DAMAGE.

CHARGING PROCEDURES

In addition to conventional charging procedures, the following requirements shall be followed. Ensure that contamination of different refrigerants does not occur when using charging equipment. Hoses or lines shall be as short as possible to minimize the amount of refrigerant contained in them. Cylinders shall be kept in an appropriate position according to the instructions. Ensure that the REFRIGERATING SYSTEM is grounded prior to charging the system with refrigerant. Fill in the label provided on the unit when charging is complete. Extreme care shall be taken not to overfill the REFRIGERATING SYSTEM. Prior to charging the system, it shall be pressure-tested with the appropriate purging gas. The system shall be leak-tested on completion of charging but prior to commissioning. A follow up leak test shall be carried out prior to leaving the site.

Final Charge Adjustment

The outdoor temperature must be 60°F or higher. Set the room thermostat to full load COOL, fan switch to AUTO, and set the temperature control well below room temperature.

After system has stabilized per startup instructions, check subcooling and superheat as detailed in the following section.

Expansion Valve System

NOTE: Expansion valve bulb must be in place on suction line & insulated.

Expansion Valve Indoors TXV Adjustment

At stabilized full load cooling conditions and with an outdoor temperature of 60°F or higher, the system should have from 14°F to 18°F subcooling. For a proper subcooling reading, measure the refrigerant pressure and temperature at the outdoor unit's liquid line service valve. If you have less than 14°F subcooling, slowly adjust the charge by adding refrigerant. If you have more than 18°F subcooling, slowly adjust the charge by removing refrigerant. The unit should have 7-11 °F superheat. Measure the suction pressure at the service valve and the evaporator temperature of each circuit at the indoor unit prior to the tee that combines the flow paths. Do the following to adjust super heat:

- If subcooling and superheat are low, adjust TXV superheat, then check subcooling. **NOTE:** To adjust superheat, turn the valve stem clockwise to increase and counterclockwise to decrease.
- If subcooling is low and superheat is high, add charge to raise subcooling then check superheat
- If subcooling and superheat are high, adjust TXV valve superheat, then check subcooling.
- If subcooling is high and superheat is low, adjust TXV valve superheat and remove charge to lower the subcooling.

NOTE: Ensure that the indoor airflow is between 350 to 400 cfm/ton. Use the airflow table in the indoor installation instruction. Wait at least 10 minutes before taking readings and making further adjustments for the system to stabilize.

Defrost Control Adjustments

This heat pump uses a Time/Temperature method for defrost. A thermal sensor electrically set to "Normally Open" is wired to the electronic defrost control located in the control box. The thermal sensor attached to the condenser coil determines the outdoor coil temperature.

Both coil temperature and compressor "run time" determine defrosting of the outdoor coil. Adjustments to the defrost timing selection can be changed from the 60 minute factory setting to either 30 or 90 minutes by moving the jumper on the defrost control. For applications with line sets between 75 feet and 150 feet, the Medium (60 minute) setting is required to assure adequate oil return. For the system to initiate a defrost, the following statements must be true:

- The Defrost Sensor is closed, and
- The compressor "run time" is equal to the timing selection on the defrost board.

TROUBLESHOOTING ANALYSIS TABLE

COMPLAINT	PROBABLE CAUSE	REMEDY
High Head Pressure	<ol style="list-style-type: none"> 1. Excessive charge of refrigerant in the system 2. Inadequate supply of air across the condenser coil. 3. Non-condensate gases in the system. 	<ol style="list-style-type: none"> 1. Purge or pump-down excessive charge. 2. Make certain that coil is not fouled in any way, or that air is not re-circulating. 3. Purge these gases from the system. Recharge system, if necessary.
Low Head Pressure	<ol style="list-style-type: none"> 1. System low on refrigerant. 2. Compressor valve broken. 	<ol style="list-style-type: none"> 1. Charge system until sight glass is clear of bubbles. 2. Replace compressor.
Low Suction Pressure	<ol style="list-style-type: none"> 1. Liquid line valve closed. 2. Restricted liquid line. 3. The bulb of the thermal expansion valve has lost its charge. 4. System low on refrigerant. 5. Dirty filters. 6. Coil frosted up. 7. Flash gas in the liquid line. 8. Quantity of air through evaporator not adequate. 	<ol style="list-style-type: none"> 1. Open the liquid line. 2. Replace filter-dryer. 3. Detach the bulb from the suction line and hold in one hand. If no liquid refrigerant goes through the valve, replace the valve. 4. Test the unit for leaks. Add refrigerant until sight glass is free from bubbles, after repairing leak. 5. Clean or replace filter. 6. Defrost and clean coil. Clean or replace filters. 7. Excessive liquid line drop. Check liquid line size. 8. Increase the blower speed.
High Suction Pressure	<ol style="list-style-type: none"> 1. Expansion valve stuck open. 2. Expansion valve bulb not in contact with suction line. 3. Suction and/or discharge valve leaking or broken. 	<ol style="list-style-type: none"> 1. Correct valve action or replace the valve. 2. Fasten bulb securely to suction line. 3. Replace compressor.
Compressor will not start.	<ol style="list-style-type: none"> 1. Disconnect switch open (if equipped). 2. Blown fuse or fuse at disconnect switch (if equipped). 3. Thermostat set too high. 4. Selector switch in "OFF" position. 5. Contactor and/or relay coils burned out. 6. Loose or open electrical connection in either the control or power circuit. 	<ol style="list-style-type: none"> 1. Close the disconnect switch (if equipped). 2. Check the cause of failure and replace the fuse (if equipped). 3. Adjust to lower temperature. 4. Turn selector switch knob to "Cool" position. 5. Replace contactor and/or relay. 6. Inspect and secure all electrical connections.

During defrost the following actions occur:

1. The reversing valve is energized and the heat pump operates in the cooling mode.
2. The air handler auxiliary heat (if equipped) is activated.
3. The condenser fan motor is shut-off.

If the defrost cycle has not terminated after ten (10) minutes the control will override the defrost sensor and revert to a heating mode.



The defrost control has test pins which can be useful when troubleshooting in the heating mode. These test pins accelerate the compressor run time counter. The suggested method for accessing this feature is:

1. Run unit in heat mode.
2. Check unit for proper charge.
NOTE: Bands of frost indicate low refrigerant charge.
3. Shut off power to unit.

Compressor Arrangement

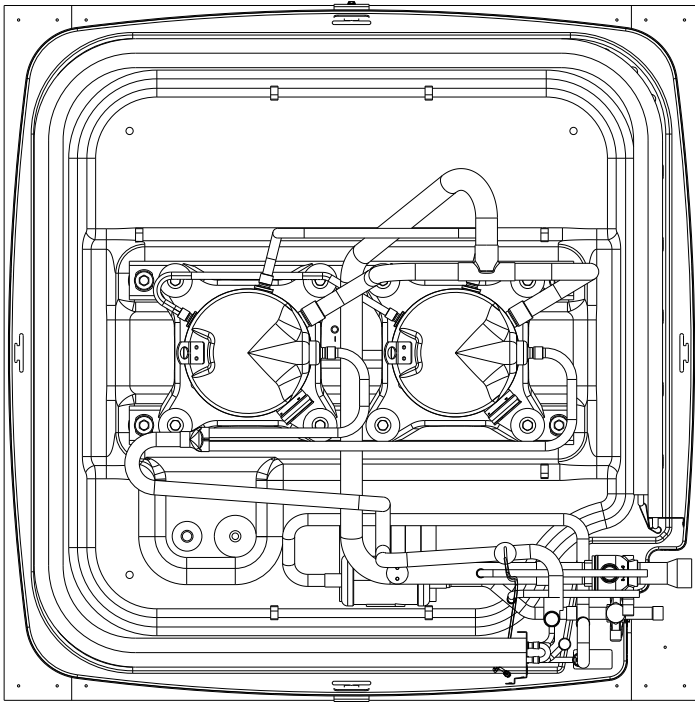

The compressors are a tandem assembly as shown below.



	WARNING
HIGH VOLTAGE DISCONNECT ALL POWER BEFORE SERVICING OR INSTALLING THIS UNIT. MULTIPLE POWER SOURCES MAY BE PRESENT. FAILURE TO DO SO MAY CAUSE PROPERTY DAMAGE, PERSONAL INJURY OR DEATH.	
	

4. Disconnect outdoor fan by removing the white lead from the defrost board on DF2.
5. Restart unit and allow frost to accumulate.

6. After a few minutes the defrost thermostat should close. To verify the position of the thermostat check for 24V between "DFT" and "C" on the defrost board. Should the defrost thermostat fail to close after a heavy build-up of frost and the thermostat is less than 28°, the thermostat is to be replaced.
7. After the thermostat has closed, short across the test pins with the a screwdriver blade until the reversing valve shifts. This could take up to 22 seconds depending upon the position of the timing setting on the defrost board. Immediately upon the action of the reversing valve, remove the short. **NOTE:** If this short is not removed immediately, the defrost activity will last only 3 seconds.
8. After defrost has terminated (up to 10 minutes) check the defrost thermostat for 24V between "DFT" and "C". This reading should be 0V (open sensor).
9. Shut off power to the unit.

	WARNING
HIGH VOLTAGE DISCONNECT ALL POWER BEFORE SERVICING OR INSTALLING THIS UNIT. MULTIPLE POWER SOURCES MAY BE PRESENT. FAILURE TO DO SO MAY CAUSE PROPERTY DAMAGE, PERSONAL INJURY OR DEATH.	
	

10. Replace outdoor fan motor wire removed in Step 4.

NOTE: The compressor "run time" is accumulative during multiple heating cycles. The timer will reset to zero only when the defrost sensor returns to an open condition. If the room thermostat is operating in the "EM HT" mode, no accumulation of compressor time is recorded.

TROUBLESHOOTING

Qualified Installer/Service only

When troubleshooting, the first step should always be to check for clean coils, clean filter(s), and proper airflow. Indoor airflow should be 375 to 425 CFM per ton of cooling based on the size of the outdoor unit. The most common way of establishing indoor airflow is heating temperature rise. Indoor airflow will then be (Heating output of equipment) / (1.1 x temp. rise). In other cases, measurement of external static pressure is helpful. For details, see the Installation Instructions for your indoor unit.

Common Causes for Unsatisfactory Operation of Heat Pumps in Heating Mode

DIRTY FILTERS

Dirty filters or inadequate airflow through the indoor coil. Failure to keep clean filters and adequate airflow (375 - 425 CFM/ton) will cause excessive discharge pressures that may cause the high-pressure switch to function.

LOW RETURN AIR TEMPERATURES

Return ductwork temperatures that are less than 60°F will cause low discharge pressure, low suction pressure and excessive defrost cycling.

UNDERCHARGING

An undercharged system will cause low discharge pressure, low suction pressure and an accumulation of frost on the lower section of the outdoor coil.

Poor Termination of Defrost

The defrost sensor must make good contact with the outside coil return bend or a non-termination of defrost may occur.

REVERSING VALVE

A reversing valve may not function correctly for the following reasons:

- 1. Solenoid does not energize when voltage is present** - Replace the reversing valve.
- 2. No voltage to the solenoid** - Check wiring.
- 3. The valve will not shift**
 - a. Undercharged - Check for leaks.
 - b. Valve body damage - Replace reversing valve.
 - c. Valve sticking - Replace the reversing valve.

CONTROL BOX COMPONENTS

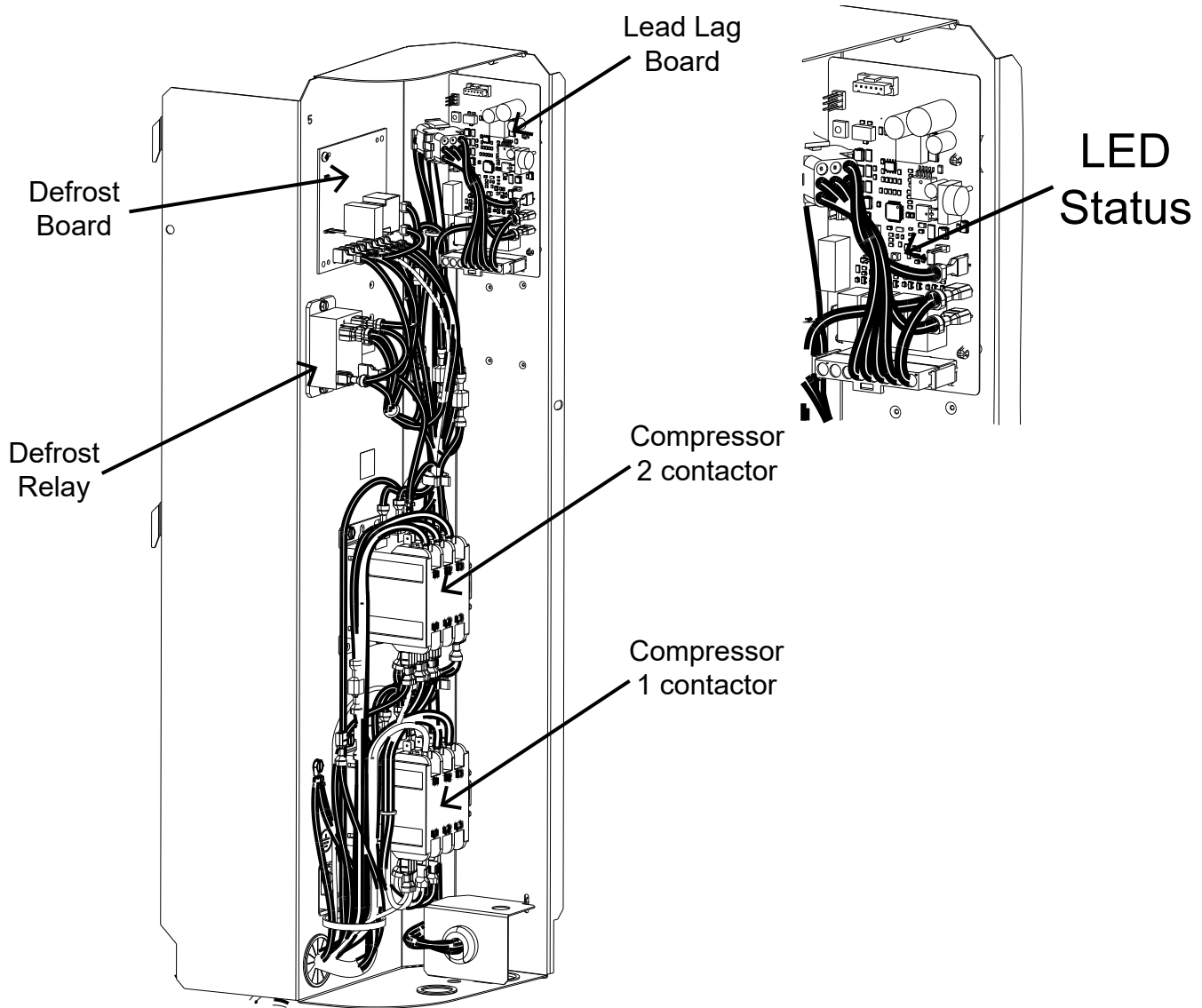

RED LED'S STATUS FLASHING PATTERNS		
	MODE	FLASHING PATTERN
1	Normal Mode (with oil returned enabled)	Continuous Blink LED
2	Normal Mode (with oil return disabled)	Solid LED

LEAD/LAG CONTROL BOARD

The Lead/Lag board will provide control logic to the compressors. The boards features are Staggered Start, Oil Return, swapping of which compressor is tied to Y1, and Anti Short Cycle timers for each compressor output. The outputs from the control board will be overridden by R-32 mitigation controls.

WIRING DIAGRAM



WARNING

HIGH VOLTAGE!
 DISCONNECT ALL POWER BEFORE SERVICING OR INSTALLING THIS UNIT.
 MULTIPLE POWER SOURCES MAY BE PRESENT. FAILURE TO DO SO MAY
 CAUSE PROPERTY DAMAGE, PERSONAL INJURY OR DEATH.

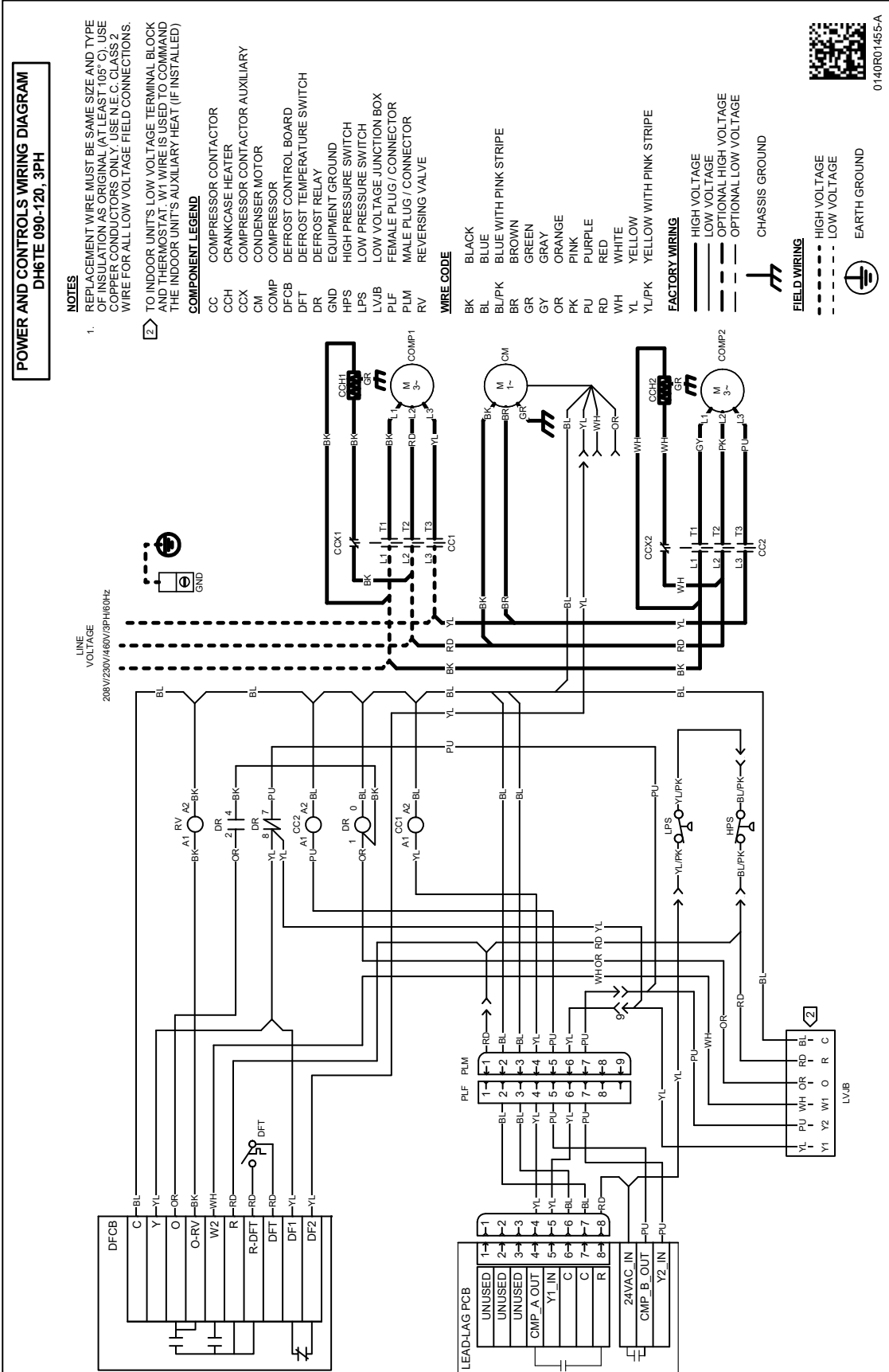

Wiring is subject to change, always refer to the wiring diagram on the unit for the most up-to-date wiring.

PAGE LEFT INTENTIONALLY BLANK.

PAGE LEFT INTENTIONALLY BLANK.

PAGE LEFT INTENTIONALLY BLANK.

CUSTOMER FEEDBACK

Daikin is very interested in all product comments.
Please fill out the feedback form on the following link:
<https://daikincomfort.com/contact-us>

You can also scan the QR code on the right to be directed to the feedback page.



Our continuing commitment to quality products may mean a change in specifications without notice.

© 2024 **DAIKIN COMFORT TECHNOLOGIES MANUFACTURING, L.P.**

19001 Kermier Rd. Waller, TX 77484

www.daikincomfort.com